

Prime Conduit™ Intra-Gard® Multi-Cell Raceway

4-Way Intra-Gard®
6-Way Intra-Gard®
Hybrid Intra-Gard®
Accessories



4-Way, 6-Way & Hybrid Intra-Gard®

Prime Conduit™ Intra-Gard® is a multi-cell raceway system used in direct bury and concrete encased applications.

Intra-Gard is available in Type C and Schedule 40 wall types and is manufactured with extended length bell ends to facilitate assembly and ensure joint integrity. Factory installed spacers provide proper spacing and alignment throughout the system. And for precise 20' lay lengths, Intra-Gard is supplied in 20'3" sticks.

Features:

- Pre-lubricated ducts – reduces coefficient of friction, thus allowing longer cable pulls
- Meets Bellcore GR356-CORE coefficient of friction requirements
- Schedule 40 and Type C wall types
- Factory installed spacers
- Multiple color configurations available for easy duct identification
- Extended length bell ends available on request
- Standard colors – white and grey

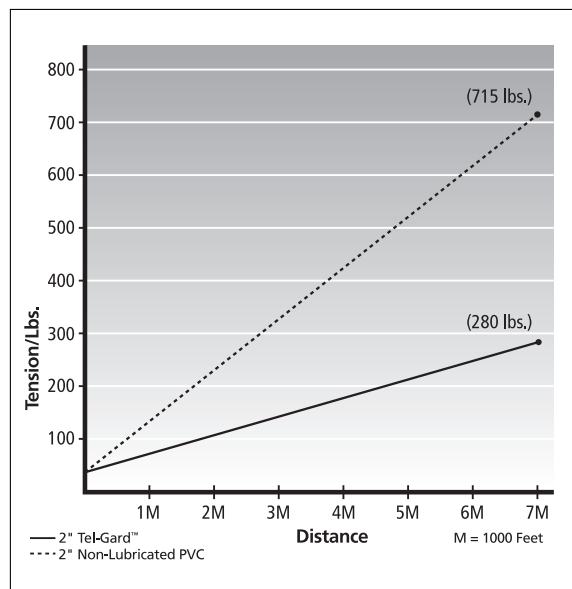

Calculated using MDPE F/O cable (Wgt.= .11 lbs./ft.)

Applications

Schedule 40

- Direct bury
- Concrete encased

Type C

- Concrete encased
- Direct bury

4-Way Intra-Gard



Standard - Two Color

	Wall type	Part Number	Color	Maximum O.D.	Minimum I.D.	Wall Thickness	
						Min.	Max.
1 1/4"	Schedule 40	I4SFG-020	1 White, 3 Grey	1.67	1.34	.13	.15
	Schedule 40	I4SFGG-020	1 White, 3 Green	1.67	1.34	.13	.15
	Type C	I4SXG-020	1 White, 3 Grey	1.67	1.46	.08	.10
1 1/2"	Schedule 40	I41540-020	1 White, 3 Grey	1.91	1.57	.15	.17
	Type C	I415C-020	1 White, 3 Grey	1.90	1.66	.10	.12
2"	Schedule 40	I42240-020	1 White, 3 Grey	2.38	2.02	.15	.17

Multi-Color Options

	Wall type	Part Number	Color	Max. O.D.	Min. I.D.	Wall Thickness	
						Min.	Max.
1 1/4"	Schedule 40	I4SFGB-020	Grey, White, Red & Orange	1.67	1.34	.13	.15
	Schedule 40	I4SFGA-020	Orange, Green, Blue & Yellow	1.67	1.34	.13	.15
	Schedule 40	I4SFG6-020	Green, Yellow, Red & Black	1.67	1.34	.13	.15
	Schedule 40	I4SFG4-020	Grey, White, Green & Orange	1.67	1.34	.13	.15
	Schedule 40	I4SFG5-020	Grey, White, Blue & Orange	1.67	1.34	.13	.15
1 1/2"	Schedule 40	I41540MC-020	Grey, White, Blue & Orange	1.91	1.57	.15	.17
	Type C	I415CMC-020	Grey, White, Blue & Orange	1.90	1.66	.10	.12
2"	Schedule 40	I42240MC-020	Grey, White, Blue & Orange	2.38	2.02	.15	.17

6-Way Intra-Gard



Standard - Two Color

	Wall type	Part Number	Color	Maximum O.D.	Minimum I.D.	Wall Thickness	
						Min.	Max.
1 1/4"	Schedule 40	I6SFG-020	1 White, 5 Grey	1.67	1.34	.13	.15
	Type C	I6SXG-020	1 White, 5 Grey	1.67	1.46	.08	.10
2"	Schedule 40	I62240-020	1 White, 5 Grey	2.38	2.02	.15	.17
	Type C	I622C-020	1 White, 5 Grey	2.38	2.16	.08	.11

4-Way Hybrid 2" & 1 1/4"



Standard - Two Color

Wall type	Part Number	Color
Schedule 40	I41240-020	1 White, 3 Grey
Type C	I412C-020	1 White, 3 Grey

Multi-Color Options

Wall type	Part Number	Color
Schedule 40	I41240MC-020	Grey, White, Blue & Orange
Type C	I412CMC-020	Grey, White, Blue & Orange

Specifications

	Wall Type	Max. O.D.	Min. I.D.	Wall Thickness	
				Min.	Max.
1 1/4"	Schedule 40	1.67	1.34	.13	.15
	Type C	1.67	1.46	.08	.10
2"	Schedule 40	2.38	2.02	.15	.17
	Type C	2.38	2.16	.08	.11

Shipping Quantities

Type	Pallet Qty.	Truck Load
4-way 1 1/4"	1,200 ft.	14,400 ft.
4-way 1 1/2"	1,200 ft.	14,400 ft.
4-way 2"	1,200 ft.	14,400 ft.
6-way 1 1/4"	720 ft.	8640 ft.
6-way 2"	720 ft.	8640 ft.
4-way Hybrid 2" x 1 1/4"	1,200 ft.	14,400 ft.

Unloading

When unloading Intra-Gard from the delivery truck, mechanical equipment should be used. If possible, distribute the Intra-Gard along the route of the trench site as it is unloaded.



Fixed Elbows

Intra-Gard® elbows are available in 3' and 4' radii and 11 1/4°, 22 1/2°, 45° and 90° angles of curvature. They are manufactured with system compatible bell and spigot ends, and are grey in color.

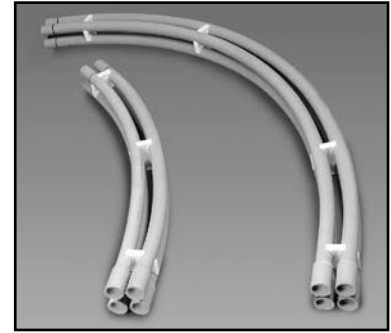

4-Way - 1 1/4"

Wall Type	Part No.	Angle	Radius	Length
Schedule 40	IF9HG4	90°	48"	81"
Schedule 40	IF9FG4	90°	36"	81"
Schedule 40	IF7HG4	45°	48"	43"
Schedule 40	IF7FG4	45°	36"	43"
Schedule 40	IF5HG4	22 1/2°	48"	26"
Schedule 40	IF5FG4	22 1/2°	36"	26"
Schedule 40	IF3HG4	11 1/4°	48"	15"
Schedule 40	IF3FG4	11 1/4°	36"	15"
Type C	IX9HG4	90°	48"	81"
Type C	IX9FG4	90°	36"	81"
Type C	IX7HG4	45°	48"	43"
Type C	IX7FG4	45°	36"	43"
Type C	IX5HG4	22 1/2°	48"	26"
Type C	IX5FG4	22 1/2°	36"	26"
Type C	IX3HG4	11 1/4°	48"	15"
Type C	IX3FG4	11 1/4°	36"	15"

6-Way - 1 1/4"

Wall Type	Part No.	Angle	Radius	Length
Schedule 40	IF9HG6	90°	48"	81"
Schedule 40	IF9FG6	90°	36"	81"
Schedule 40	IF7HG6	45°	48"	43"
Schedule 40	IF7FG6	45°	36"	43"
Schedule 40	IF5HG6	22 1/2°	48"	26"
Schedule 40	IF5FG6	22 1/2°	36"	26"
Schedule 40	IF3HG6	11 1/4°	48"	15"
Schedule 40	IF3FG6	11 1/4°	36"	15"
Type C	IX9HG6	90°	48"	81"
Type C	IX9FG6	90°	36"	81"
Type C	IX7HG6	45°	48"	43"
Type C	IX7FG6	45°	36"	43"
Type C	IX5HG6	22 1/2°	48"	26"
Type C	IX5FG6	22 1/2°	36"	26"
Type C	IX3HG6	11 1/4°	48"	15"
Type C	IX3FG6	11 1/4°	36"	15"

Hybrid - 2" & 1 1/4"

Wall Type	Part No.	Angle	Radius	Length
Schedule 40	I4129040	90°	36"	39"
Schedule 40	I4124540	45°	36"	67"

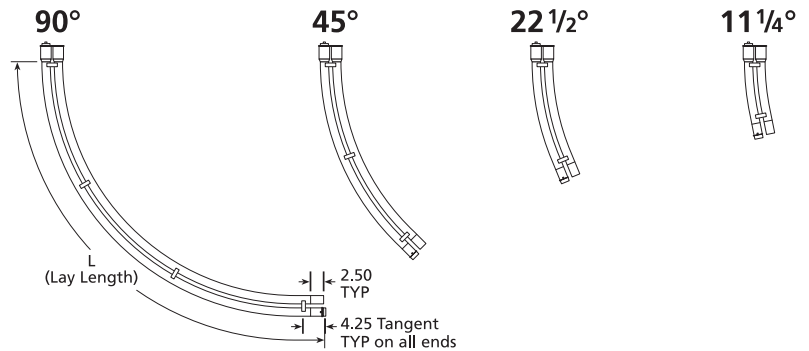

End Bell Terminator Ring

Manhole Terminator or Handhole Entrance

At the manhole or handhole entrance, the ideal termination procedure is to use commercially available industry standard Type C duct end bell (4.35") precast into the manhole or handhole wall. To properly seal the Intra-Gard® at its termination points, Intra-Gard manhole terminator rings are available as a 1" thick disk designed to properly space the innerducts and fit into a 4.35" O.D. (Part #IRS4 .)

1. Align the ducts with the Intra-Gard terminator spacer ring and insert spigot ends through holes provided.
2. Insert prepared male end into the precast terminator. The terminator should be solvent cemented into the precast terminator or sealed around outside of the entrance as required by the job specifications.
3. Duct plugs should be used (MAEPG3) after installation on empty ducts to avoid water and dust infiltration.

Other Type Entrances

1. Where a knockout is used, the procedure starts with inserting the male end of the section of pipe four inches past the inside wall of the manhole or handhole. Insert terminator and align the ducts with Intra-Gard terminator ring. Seal around entrance as required by the job specifications.
2. A pass through terminator may be secured into wall of manhole or handhole either directly into precast terminator or grout in place if knockout is used.



Terminator Ring

Part No.	Description
IRS4	4-Way 1 1/4" Terminator Ring

* Manhole terminator sold separately

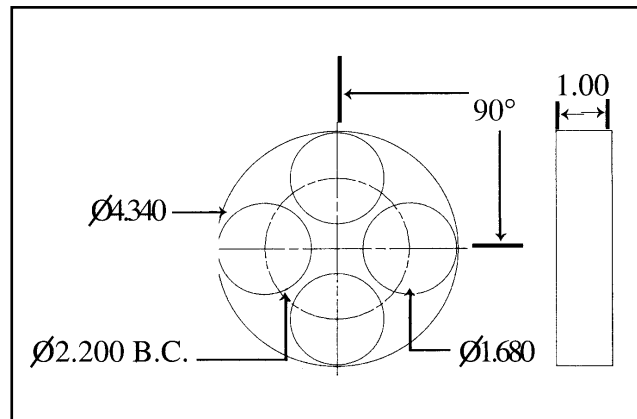

Upon completion of conduit placement, install ducts to traverse manhole/handhole by cutting to length, inserting into one side of handhole, and raising or bowing center of duct span to insert in the pass through terminator on the other side.

3. Pass through application may be accomplished by installing a long line coupling onto each duct entering the vault. Couplings should then be solvent cemented onto each remaining duct of Intra-Gard.

Installation Instructions

When handling Intra-Gard®, care must be taken to avoid striking the ends against hard surfaces. This can cause damage from impact or crushing of the end of the conduit.

Assembly In Trench

1. In the trench, set the first layer of ducts by inserting the male ends into the female ends on the sections previously placed. Make sure the matching colors are aligned.



2. A thin coating of Quick Set Cement should be applied to the inside surface of the sockets lightly enough to prevent the formation of a bead of cement at the interior shoulder of the sockets. Then, apply in the same manner to the spigot ends of the conduits to the depth of the socket.
3. Immediately after applying the coat of cement to the conduit, insert the spigot ends into the sockets.



Duct Proofing

Use appropriate seal-off kit. For maximum line blowing potential, use air compressor at 175 CFM (125 PSI Max.)

1. Slide pull line through opening in threaded nozzle end of seal-off. Attach blowing missile to pull line.
2. Insert blowing missile into individual duct and insert threaded end of seal-off into duct to assure minimal air loss.
3. Attach seal-off to air compressor with air release lever in off position. Hold seal off firmly in hands.
4. Open lever quickly making sure slight tension is on to prevent pull line from packing. **CAUTION SHOULD BE EXERCISED AT THE EXIT POINT FOR MISSILE TO AVOID INJURY.** Blow pull line in all ducts to ensure no blockages are present.

Field Cuts

Joining a Male/Female Connection

1. The pipes should be laid side by side and the male end marked at the base of the bell on the female end.
2. Make a straight through cut on the male end using a standard carpenter's saw. Deburr the ends of the cut pipe.
3. Apply Quick Set Cement in a thin uniform coating to the inside surface of the sockets and raise both ends and align the ducts on the male ends to the bells on the female end.
4. Once the ducts are aligned with their sockets, lower both of the pipes. The ducts will be automatically returned to their original position as the joints are forced together.



Joining Two Male Ends

1. The pipes should be laid side by side, marked and flush cut to butt up against each other. Deburr the ends of the cut pipe and install a spare spacer if needed, and use standard couplings.
2. Place each individual coupling onto ducts using Quick Set Cement.
3. Lift sections to align each coupling with other ducts.
4. Lower both sections to a level position.

Repairing Intra-Gard® Once Installed

Repair sections may use a standard 20' length of Intra-Gard with sockets and cut to length.

Repairing Damaged Intra-Gard That Is Vacant

1. Cut out damaged section making a flush cut on both sides and deburr all pipes.
2. Measure damaged section and new section with a socket and measure from base of socket and cut flush. Intra-Gard couplings are installed onto the individual ducts of the section in the ground.
3. Install new section in trench by first applying Quick Set Cement and pushing sockets onto either spigot ends.
4. Line up ducts with couplings and raise or bow center of duct span, apply cement and slip ducts into couplings.

Repairing Intra-Gard Housing a Cable

1. Carefully cut out the damaged section of the Intra-Gard.
2. Where cable is installed, slide the split couplings onto each individual duct, fitting the cable into the grooved coupling passage. Repeat the process on the other side.
3. Carefully insert the cable into the split duct. Push the split duct into the split coupling at both ends. Wrap all slit areas with sealing tape or shrink wrap, etc. as recommended by specifier to seal out water.
4. Install stop coupling onto other vacant ducts with Quick Set Cement and install the ducts into the other openings of the couplings with cement.
5. Ensure the duct system is straight and even before encasing in soil.

Prime Conduit™ Intra-Gard® Quote Request

Date: _____ Needed By: _____

Destination: _____

Customer: _____

Account Number: _____

Rep Agency: _____

Market: _____ Power _____ Telecommunication

Total Quantity Feet: _____

Target Price: _____

Quoted Price: _____

Competitors Price: _____

Quoted Terms: _____

Freight Terms: _____

Valid Until: _____

Quoted By: _____

4-Way Intra-Gard

Standard - Two Color

	Wall type	Part No.	Qty.
1 1/4"	Schedule 40	I45FG-020	
	Schedule 40	I45FGG-020	
	Type C	I45XG-020	
1 1/2"	Schedule 40	I41540-020	
	Type C	I415C-020	
2"	Schedule 40	I42240-020	

Multi-Color Options

	Wall type	Part No.	Qty.
1 1/4"	Schedule 40	I45FGB-020	
	Schedule 40	I45FGA-020	
	Schedule 40	I45FG6-020	
	Schedule 40	I45FG4-020	
	Schedule 40	I45FG5-020	
1 1/2"	Schedule 40	I41540MC-020	
	Type C	I415CMC-020	
2"	Schedule 40	I42240MC-020	

Fixed Elbows - 4 Way 1 1/4"

Schedule 40

Part No.	Angle	Radius	Qty.
IF9HG4	90°	48"	
IF9FG4	90°	36"	
IF7HG4	45°	48"	
IF7FG4	45°	36"	
IF5HG4	22 1/2°	48"	
IF5FG4	22 1/2°	36"	
IF3HG4	11 1/4°	48"	
IF3FG4	11 1/4°	36"	

Type C

Part No.	Angle	Radius	Qty.
IX9HG4	90°	48"	
IX9FG4	90°	36"	
IX7HG4	45°	48"	
IX7FG4	45°	36"	
IX5HG4	22 1/2°	48"	
IX5FG4	22 1/2°	36"	
IX3HG4	11 1/4°	48"	
IX3FG4	11 1/4°	36"	

6-Way Intra-Gard

Standard - Two Color

	Wall type	Part No.	Qty.
1 1/4"	Schedule 40	I65FG-020	
	Type C	I65XG-020	
2"	Schedule 40	I62240-020	
	Type C	I622C-020	

Fixed Elbows - 6 Way 1 1/4"

Schedule 40

Part No.	Angle	Radius	Qty.
IF9HG6	90°	48"	
IF9FG6	90°	36"	
IF7HG6	45°	48"	
IF7FG6	45°	36"	
IF5HG6	22 1/2°	48"	
IF5FG6	22 1/2°	36"	
IF3HG6	11 1/4°	48"	
IF3FG6	11 1/4°	36"	

Type C

Part No.	Angle	Radius	Qty.
IX9HG6	90°	48"	
IX9FG6	90°	36"	
IX7HG6	45°	48"	
IX7FG6	45°	36"	
IX5HG6	22 1/2°	48"	
IX5FG6	22 1/2°	36"	
IX3HG6	11 1/4°	48"	
IX3FG6	11 1/4°	36"	

4-Way Hybrid 2" & 1 1/4" Intra-Gard

Standard - Two Color

Wall type	Part No.	Qty.
Schedule 40	I41240-020	
Type C	I412C-020	

Multi-Color Options

Wall type	Part No.	Qty.
Schedule 40	I41240MC-020	
Type C	I412CMC-020	

Fixed Elbows - Hybrid 2" & 1 1/4"

Wall type	Part No.	Angle	Radius	Qty.
Schedule 40	I4129040	90°	36"	
Schedule 40	I4124540	45°	36"	

Accessories

Pull Line

Part No.	Qty.

Plugs

Part No.	Qty.

Line Blowing Accessories

Part No.	Qty.

Spacers

Part No.	Qty.

Warning Tape

Part No.	Qty.

Cutters

Part No.	Qty.

NOTE: Please fill in desired part number and quantities.

Fax completed Quote Request to your Local Prime Conduit Representative. Visit www.primeconduit.com to locate a Prime Conduit Representative.