

Prime Conduit™ Schedule 40 & 80 Conduit & Elbows

Schedule 40 Conduit

Schedule 80 Conduit

✦ *Schedule 40 Conduit*

Schedule 40 Elbows

Schedule 80 Elbows

✦ *Schedule 40 Elbows*

Properties

Expansion & Contraction

Corrosion Resistance

Specification

*Schedule 40
Utility Conduit & Elbows*



Prime Conduit™ Rigid Nonmetallic Conduit (RNC)

Prime Conduit™ manufactures the most complete line of nonmetallic conduits in the electrical industry. Prime Conduit Schedule 40 and Schedule 80 conduits are designed for use aboveground and underground as described in the National Electrical Code. Specify only Prime Conduit conduits to insure raceway system quality.

Features

Ease of Installation Nonmetallic conduits are 1/4 to 1/5 the weight of metallic systems, can be installed in less than half the time, and are easily fabricated on the job.

Safety Nonmetallic conduits are nonconductive, assuring a safe system.

Impact Resistant Prime Conduit Schedule 40 and Schedule 80 nonmetallic conduits are resistant to sunlight and are listed for exposed or outdoor usage.

Corrosion Resistant Prime Conduit conduits are nonmetallic and will not rust or corrode.

Prime Conduit nonmetallic Schedule 40 and Schedule 80 conduits and elbows are manufactured to NEMA TC-2, Federal specification WC1094A and UL 651 specifications. The conduit carries respective UL or ETL Listings and UL or ETL labels.

Prime Conduit Schedule 40 PVC Rigid Nonmetallic Conduit (RNC). (Heavy Wall EPC)

Listed for underground applications encased in concrete or direct burial. Also for use in exposed or concealed applications aboveground.

- Sunlight resistant • Rated for use with 90°C conductors
- Superior weathering characteristics • Made in USA



RUS Accepted

Schedule 40 Heavy Wall

With Integral Bell*



Part No.		Trade Size	Std. Crate Qty.		Wt. Per 100'	Dimensions		
10'	20'		10'	20'		O.D.	I.D.	Wall
49005-010		1/2"	6000'		17	.840	.622	.109
49007-010	49007-020	3/4"	4400'	8800'	23	1.050	.824	.113
49008-010	49008-020	1"	3600'	7200'	34	1.315	1.049	.133
49009-010	49009-020	1 1/4"	3300'	6600'	46	1.660	1.380	.140
49010-010	49010-020	1 1/2"	2250'	4500'	55	1.900	1.610	.145
49011-010	49011-020	2"	1400'	2800'	73	2.375	2.067	.154
49012-010	49012-020	2 1/2"	930'	1860'	124	2.875	2.469	.203
49013-010	49013-020	3"	880'	1760'	163	3.500	3.068	.216
49014-010	49014-020	3 1/2"	630'	1260'	196	4.000	3.548	.226
49015-010	49015-020	4"	570'	1140'	232	4.500	4.026	.237
49016-010	49016-020	5"	380'	760'	315	5.563	5.047	.258
49017-010	49017-020	6"	260'	520'	409	6.625	6.065	.280

Rigid nonmetallic conduit is normally supplied in standard 10' lengths, with one belled end per length. For specific requirements, it may be produced in lengths shorter or longer than 10', with or without belled ends.

Use RNC Fittings with Schedule 40 and Schedule 80 Conduit.

- Notes:**
1. Special conduit sizes will be quoted on request.
 2. DON'T FORGET TO ORDER CEMENT.
 3. Prime conduit reserves the right to ship to the nearest unitized quantity.

Prime Conduit Schedule 80 PVC Rigid Nonmetallic Conduit (RNC) (Extra Heavy Wall EPC-80)



Listed for use in aboveground and belowground applications including areas subject to physical damage.

- Sunlight resistant • Rated for use with 90°C conductors • Superior weathering characteristics
- Identified for use in areas subject to physical damage in accordance to 352.12(C)

RUS Accepted

With Integral Bell*



Schedule 80 Extra Heavy Wall

Part No.		Trade Size	Std. Crate Qty.		Wt. Per 100'	Dimensions		
10'	20'		10'	20'		O.D.	I.D.	Wall
49405-010	49405-020	1/2"	6000'	12000'	21	.840	.546	.147
49407-010	49407-020	3/4"	4400'	8000'	30	1.050	.742	.154
49408-010	49408-020	1"	3600'	7200'	44	1.315	.957	.179
49409-010	49409-020	1 1/4"	3300'	6600'	60	1.660	1.278	.191
49410-010	49410-020	1 1/2"	2250'	3600'	72	1.900	1.500	.200
49411-010	49411-020	2"	1400'	2800'	101	2.375	1.939	.218
49412-010	49412-020	2 1/2"	930'	1880'	154	2.875	2.323	.276
49413-010	49413-020	3"	880'	1760'	210	3.500	2.900	.300
49415-010	49415-020	4"	570'	1140'	308	4.500	3.826	.337
49416-010	—	5"	380'	—	428	5.563	4.813	.375
49417-010	49417-020	6"	260'	520'	588	6.625	5.761	.432

Rigid nonmetallic conduit is normally supplied in standard 10' lengths, with one belled end per length. For specific requirements, it may be produced in lengths shorter or longer than 10', with or without belled ends.

Use RNC Fittings with Schedule 40 and Schedule 80 Conduit.

- Notes: 1. Special conduit sizes will be quoted on request.
2. DON'T FORGET TO ORDER CEMENT.
3. Prime Conduit reserves the right to ship to the nearest unitized quantity.

Support of Prime Conduit Rigid Nonmetallic Conduit in Aboveground Installations

Table 352.30(B) NEC shows the support requirements for Schedule 40 and Schedule 80 rigid PVC nonmetallic conduit.

Plastic conduit should always be installed away from steam lines, etc. Support straps should allow for lineal movement caused by expansion and contraction.

Maximum ambient temperature is 122°F (50°C).

Table 352.30(B), NEC

Trade Size	Maximum Spacing Between Supports (feet)
1/2 - 1	3
1 1/4 - 2	5
2 1/2 - 3	6
3 1/2 - 5	7
6	8

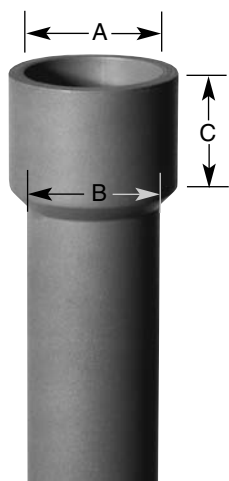

Acceptable Dimensions in Inches of Integral Bell per UL 651

Trade Size	A		B		C
	At Entrance (in.)	Minimum	At Bottom (in.)	Minimum	
1/2	0.860	0.844	0.844	0.828	1.375
3/4	1.074	1.054	1.056	1.036	1.500
1	1.340	1.320	1.320	1.300	1.750
1 1/4	1.689	1.665	1.667	1.643	1.875
1 1/2	1.930	1.906	1.906	1.882	2.750
2	2.405	2.381	2.381	2.357	3.250
2 1/2	2.905	2.875	2.883	2.853	3.250
3	3.530	3.500	3.507	3.477	3.875
3 1/2	4.065	3.965	4.007	3.977	3.875
4	4.565	4.465	4.506	4.476	4.625
5	5.643	5.543	5.583	5.523	5.625
6	6.708	6.608	6.644	6.584	6.375

Prime Conduit Schedule 40 PVC Rigid Nonmetallic Conduit (RNC) (Heavy Wall EPC)

Certified for underground applications encased in concrete or direct burial. Also for use in exposed or concealed applications aboveground. • Sunlight resistant • Rated for use with 75°C conductors
• Superior weathering characteristics • Meets CSA Standard C22.2 No. 211.2
• 3/4" – 4" are FT-4 Rated

With Integral Bell*

Schedule 40 Heavy Wall



Part No.		Nom. Size	Std. Crate Qty.		Wt. Per 100'	Dimensions		Wall
10'	20'		10'	20'		O.D.	I.D.	
49005CC-010	49005CC-020	1/2"	6000'	12000'	17	.840	.622	.109
49007CC-010	49007CC-020	3/4"	4400'	8800'	23	1.050	.824	.113
49008CC-010	49008CC-020	1"	3600'	7200'	34	1.315	1.049	.133
49009CC-010	49009CC-020	1 1/4"	3300'	6600'	46	1.660	1.380	.140
49010CC-010	49010CC-020	1 1/2"	1800'	3600'	55	1.900	1.610	.145
49011CC-010	49011CC-020	2"	1400'	2800'	73	2.375	2.067	.154
49012CC-010	49012CC-020	2 1/2"	930'	1860'	124	2.875	2.469	.203
49013CC-010	49013CC-020	3"	880'	1760'	163	3.500	3.068	.216
49014CC-010	-	3 1/2"	630'	-	196	4.000	3.548	.226
49015CC-010	49015CC-020	4"	570'	1140'	232	4.500	4.026	.237
49016CC-010	49016CC-020	5"	380'	760'	315	5.563	5.047	.258
49017CC-010	49017CC-020	6"	260'	520'	409	6.625	6.065	.280

Acceptable Dimensions in Inches of CSA Listed Integral Bell

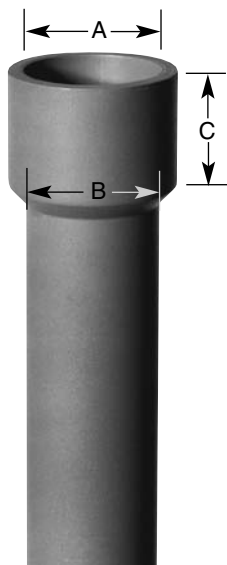

Trade Size of Conduit in Inches	A At Entrance		B At Bottom		C Socket Depth	
	Maximum	Minimum	Maximum	Minimum	Maximum	Minimum
1/2	0.860	0.844	0.844	0.828	1.500	0.652
3/4	1.074	1.054	1.056	1.036	1.500	0.719
1	1.340	1.320	1.320	1.300	1.875	0.875
1 1/4	1.689	1.665	1.667	1.643	2.000	0.938
1 1/2	1.930	1.906	1.906	1.882	2.000	1.062
2	2.405	2.381	2.381	2.357	2.000	1.125
2 1/2	2.905	2.875	2.883	2.853	3.000	1.469
3	3.530	3.500	3.507	3.477	3.125	1.594
3 1/2	4.065	3.965	4.007	3.977	3.250	1.687
4	4.565	4.465	4.506	4.476	3.375	1.750
5	5.643	5.543	5.583	5.523	3.625	1.937
6	6.708	6.608	6.644	6.584	3.750	2.125

Rigid nonmetallic conduit is normally supplied in standard 10' lengths, with one belled end per length. For specific requirements, it may be produced in lengths shorter or longer than 10', with or without belled ends.

Use RNC Fittings with Schedule 40 Conduit.

- Notes: 1. Special conduit sizes will be quoted on request.
2. DON'T FORGET TO ORDER CEMENT.
3. Prime Conduit reserves the right to ship to the nearest unitized quantity.

Rigid Nonmetallic Conduit – Elbows



ETL Listed
to UL 651 in
compliance to
the NEC



LISTED
E35297

Schedule 40 Elbows Standard Radius

Available in plain and integral belled end for use with nonmetallic solvent weld fittings.

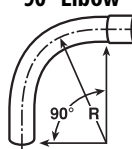
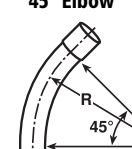
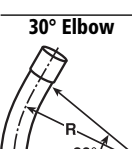
Item	Plain End Part No.	Belled End Part No.	Size	Plain End Std. Ctn. Qty.	Belled End Std. Ctn. Qty.
90° Elbow 	UA9AJ	UA9AJB	2"	20	20
	UA9AK-CAR	UA9AKB-CAR	2 1/2"	10	10
	UA9AL	UA9ALB	3"	1	5
	UA9AM	UA9AMB	3 1/2"	1	20
	UA9AN	UA9ANB	4"	1	1
	UA9AP	UA9APB	5"	1	1
UA9AR	UA9ARB	6"	1	1	
45° Elbow 	UA7AJ	UA7AJB	2"	20	20
	UA7AJ-CAR	-	2"	4	4
	UA7AK	UA7AKB	2 1/2"	20	20
	UA7AL	UA7ALB	3"	5	25
	UA7AM	UA7AMB	3 1/2"	1	20
	UA7AN	UA7ANB	4"	1	20
UA7AP	UA7APB	5"	1	1	
UA7AR	UA7ARB	6"	1	1	
30° Elbow 	UA6AJ	UA6AJB	2"	20	20
	UA6AK	UA6AKB	2 1/2"	10	20
	UA6AL	UA6ALB	3"	1	1
	UA6AM	UA6AMB	3 1/2"	1	1
	UA6AN	UA6ANB	4"	1	1
	UA6AP	UA6APB	5"	1	1
UA6AR	UA6ARB	6"	1	1	

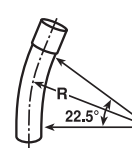
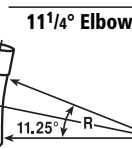
Item	Plain End Part No.	Belled End Part No.	Size	Plain End Std. Ctn. Qty.	Belled End Std. Ctn. Qty.
22 1/2° Elbow 	UA5AJ	UA5AJB	2"	25	1
	UA5AK	-	2 1/2"	20	-
	UA5AL	UA5ALB	3"	5	1
	UA5AM	-	3 1/2"	1	-
	UA5AN	UA5ANB	4"	1	1
	UA5AP	UA5APB	5"	1	1
UA5AR	UA5ARB	6"	1	1	
11 1/4° Elbow 	UA3AJ	-	2"	1	-
	UA3AK	-	2 1/2"	1	-
	UA3AL	-	3"	1	-
	UA3AM	-	3 1/2"	1	-
	UA3AN	UA3ANB	4"	1	1
	UA3AP	-	5"	1	-
UA3AR	-	6"	1	-	

Standard Radius Elbow Dimensions

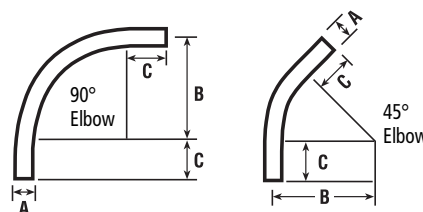

Integral Belled End Dimensions

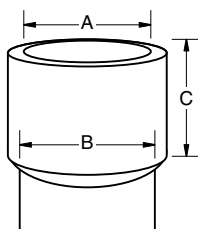

Trade Size	A		B		C	
	At Entrance Max.	Min.	At Bottom Max.	Min.	Socket Depth Max.	Min.
2"	2.405	2.381	2.381	2.357	2.000	1.125
2 1/2"	2.905	2.875	2.883	2.853	3.000	1.469
3"	3.530	3.500	3.507	3.477	3.125	1.594
3 1/2"	4.065	3.965	4.007	3.977	3.250	1.687
4"	4.565	4.465	4.506	4.476	3.375	1.750
5"	5.643	5.543	5.583	5.523	3.625	1.937
6"	6.708	6.608	6.644	6.584	3.750	2.125

Size	A	B Min. (Radius)	C Min.
2"	2.375	9 1/2"	2"
2 1/2"	2.875	10 1/2"	3"
3"	3.500	13"	3 1/8"
3 1/2"	4.000	15"	3 1/4"
4"	4.500	16"	3 3/8"
5"	5.563	24"	3 5/8"
6"	6.625	30"	3 3/4"

Rigid Nonmetallic Conduit – Elbows



ETL Listed to UL 651 in compliance to the NEC



LISTED E35297

Schedule 40 Elbows Special Radius

*Consult factory for additional sizes/configurations

Except where noted by ►

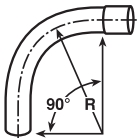
Segment	Plain End Part No.	Belled End Part No.	Nom. Diam.	Radius (in.)	Plain End Std. Ctn. Qty.	Belled End Std. Ctn. Qty.
90° Elbow 	UA9CJ	UA9CJB	2"	18"	1	1
	UA9DJ	UA9DJB-UPC	2"	24"	1	1
	UA9EJ	UA9EJB	2"	30"	1	1
	UA9FJ-UPC	UA9FJB	2"	36"	1	1
	UA9HJ	UA9HJB	2"	48"	1	1
	UA9JJ	–	2"	72"	1	–
	UA9CK	UA9CKB	2½"	18"	1	1
	UA9DK	UA9DKB-UPC	2½"	24"	1	1
	UA9EK	UA9EKB	2½"	30"	1	1
	UA9FK-UPC	UA9FKB	2½"	36"	1	1
	UA9HK	UA9HKB	2½"	48"	1	1
	UA9CL	UA9CLB	3"	18"	1	1
	UA9DL	UA9DLB-UPC	3"	24"	1	1
	UA9EL	UA9ELB	3"	30"	1	1
	UA9FL	UA9FLB	3"	36"	1	1
	UA9HL	UA9HLB	3"	48"	1	1
	UA9IL	–	3"	60"	1	–
	UA9DM	UA9DMB	3½"	24"	1	1
	UA9EM	UA9EMB	3½"	30"	1	1
	UA9FM	UA9FMB	3½"	36"	1	1
	UA9HM	UA9HMB	3½"	48"	1	1
	–	UA9CNB	4"	18"	–	1
	UA9DN	UA9DNB	4"	24"	1	1
	UA9EN	UA9ENB	4"	30"	1	1
	UA9FN	UA9FNB	4"	36"	1	1
	UA9HN	UA9HNB	4"	48"	1	1
	UA9IN	UA9INB	4"	60"	1	1
	UA9JN	–	4"	72"	1	1
	UA9EP	UA9EPB	5"	30"	1	1
	UA9FP	UA9FPB	5"	36"	1	1
	UA9HP	UA9HPB	5"	48"	1	1
	UA9IP	UA9IPB	5"	60"	1	1
	UA9FR	UA9FRB	6"	36"	1	1
	UA9HR	UA9HRB	6"	48"	1	1
	UA9IR	UA9IRB	6"	60"	1	1
	–	UA9TRB	6"	180"	–	1
	► UA9HT	–	8"	48"	1	1

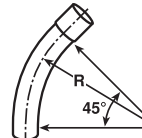
Segment	Plain End Part No.	Belled End Part No.	Nom. Diam.	Radius (in.)	Plain End Std. Ctn. Qty.	Belled End Std. Ctn. Qty.
45° Elbow 	–	UA7BJB	2"	12"	–	1
	UA7CJ	UA7CJB	2"	18"	1	1
	UA7DJ	UA7DJB	2"	24"	1	1
	UA7EJ	UA7EJB	2"	30"	1	1
	UA7FJ	UA7FJB	2"	36"	1	1
	UA7HJ	UA7HJB	2"	48"	1	1
	UA7SJ	–	2"	150"	1	–
	UA7CK	–	2½"	18"	1	–
	UA7DK	UA7DKB	2½"	24"	1	1
	UA7EK	–	2½"	30"	1	–
	UA7FK	UA7FKB	2½"	36"	1	1
	UA7HK	–	2½"	48"	1	–
	UA7CL	UA7CLB	3"	18"	1	1
	UA7DL	UA7DLB	3"	24"	1	1
	UA7EL	UA7ELB	3"	30"	1	1
	UA7FL	UA7FLB	3"	36"	1	1
	UA7HL	UA7HLB	3"	48"	1	1
	UA7DM	–	3½"	24"	1	–
	UA7EM	–	3½"	30"	1	–
	UA7FM	–	3½"	36"	1	–
	UA7DN	UA7DNB	4"	24"	1	1
	UA7EN	UA7ENB	4"	30"	1	1
	UA7FN	UA7FNB	4"	36"	1	1
	UA7HN	UA7HNB	4"	48"	1	1
	–	UA7NNB	4"	120"	–	1
	UA7SN	UA7SNB	4"	150"	1	–
	UA7EP	UA7EPB	5"	30"	1	1
	UA7FP	UA7FPB	5"	36"	1	1
	UA7HP	UA7HPB	5"	48"	1	1
	–	UA7IPB	5"	60"	–	1
–	UA7NPB	5"	120"	–	1	
–	UA7SPB	5"	150"	–	1	
UA7FR	UA7FRB	6"	36"	1	1	
UA7HR	UA7HRB	6"	48"	1	1	
► UA7FT	–	8"	36"	1	–	
► UA7HT	–	8"	48"	1	–	

Note: Elbows 72" and larger may be shipped in segments. Consult factory for specifics.

Rigid Nonmetallic Conduit – Elbows



ETL Listed to UL 651 in compliance to the NEC



LISTED E35297

Schedule 40 Elbows Special Radius

*Consult factory for additional sizes/configurations

Except where noted by ►

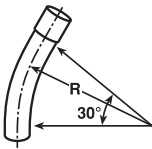
Segment	Plain End Part No.	Belled End Part No.	Nom. Diam.	Radius (in.)	Plain End Std. Ctn. Qty.	Belled End Std. Ctn. Qty.
30° Elbow 	UA6CJ	–	2"	18"	1	–
	UA6DJ	UA6DJB	2"	24"	1	1
	UA6FJ	UA6FJB	2"	36"	1	1
	UA6HJ	UA6HJB	2"	48"	1	1
	UA6CK	–	2½"	18"	1	–
	UA6DK	–	2½"	24"	1	–
	UA6CL	–	3"	18"	1	–
	UA6DL	UA6DLB	3"	24"	1	1
	UA6FL	UA6FLB	3"	36"	1	1
	UA6HL	UA6HLB	3"	48"	1	1
	UA6DM	–	3½"	24"	1	–
	UA6FM	–	3½"	36"	1	–
	UA6HM	–	3½"	48"	1	–
	UA6DN	–	4"	24"	1	–
	UA6FN	UA6FNB	4"	36"	1	1
	UA6HN	UA6HNB	4"	48"	1	1
	UA6FP	UA6FPB	5"	36"	1	1
	UA6HP	UA6HPB	5"	48"	1	1
	UA6FR	UA6FRB	6"	36"	1	1
	UA6HR	UA6HRB	6"	48"	1	1

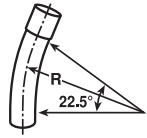
Segment	Plain End Part No.	Belled End Part No.	Nom. Diam.	Radius (in.)	Plain End Std. Ctn. Qty.	Belled End Std. Ctn. Qty.
22½° Elbow 	UA5CJ	UA5CJB	2"	18"	1	1
	UA5DJ	UA5DJB	2"	24"	1	25
	UA5EJ	UA5EJB	2"	30"	1	1
	UA5FJ	UA5FJB	2"	36"	1	1
	UA5HJ	–	2"	48"	1	–
	UA5VJ	–	2"	300"	1	–
	UA5CK	–	2½"	18"	1	–
	UA5DK	–	2½"	24"	1	–
	UA5EK	–	2½"	30"	1	–
	UA5FK	–	2½"	36"	1	–
	UA5HK	–	2½"	48"	1	–
	–	UA5CLB	3"	18"	1	1
	UA5DL	UA5DLB	3"	24"	1	1
	UA5EL	UA5ELB	3"	30"	1	1
	UA5FL	UA5FLB	3"	36"	1	1
	UA5HL	–	3"	48"	1	–
	UA5VL	–	3"	300"	1	–
	UA5DM	–	3½"	24"	1	–
	UA5EM	–	3½"	30"	1	–
	UA5FM	–	3½"	36"	1	–
	UA5HM	–	3½"	48"	1	–
	UA5DN	UA5DNB	4"	24"	1	1
	UA5EN	UA5ENB	4"	30"	1	1
	UA5FN	UA5FNB	4"	36"	1	1
	UA5HN	UA5HNB	4"	48"	1	–
	UA5IN	–	4"	60"	1	–
	UA5JN	–	4"	72"	1	–
	UA5SN	UA5SNB	4"	150"	1	–
	–	UA5UNB	4"	240"	–	1
	–	UA5VNB	4"	300"	–	1
	–	UA5DPB	5"	24"	1	1
	UA5EP	UA5EPB	5"	30"	1	1
UA5FP	UA5FPB	5"	36"	1	1	
UA5HP	UA5HPB	5"	48"	1	1	
UA5IP	–	5"	60"	1	–	
UA5SP	–	5"	150"	1	–	
–	UA5UPB	5"	240"	–	1	
–	UA5VPB	5"	300"	–	1	
UA5FR	UA5FRB	6"	36"	1	1	
UA5HR	UA5HRB	6"	48"	1	1	
UA5IR	–	6"	60"	1	–	
UA5RR	–	6"	144"	1	–	
UA5SR	–	6"	150"	1	–	
UA5VR	–	6"	300"	1	–	
UA5FT	–	8"	36"	1	–	
UA5HT	–	8"	48"	1	–	

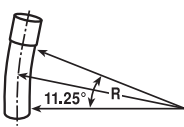
Segment	Plain End Part No.	Belled End Part No.	Nom. Diam.	Radius (in.)	Plain End Std. Ctn. Qty.	Belled End Std. Ctn. Qty.
11¼° Elbow 	UA3DJ	UA3DJB	2"	24"	1	25
	UA3FJ	UA3FJB	2"	36"	1	1
	UA3HJ	–	2"	48"	1	–
	UA3HK	–	2½"	48"	1	–
	UA3DL	UA3DLB	3"	24"	1	1
	UA3FL	UA3FLB	3"	36"	1	1
	UA3HL	–	3"	48"	1	–
	UA3DM	–	3½"	24"	1	–
	UA3HM	–	3½"	48"	1	–
	UA3DN	UA3DNB	4"	24"	1	1
	UA3FN	UA3FNB	4"	36"	1	1
	–	UA3SNB	4"	150"	–	1
	UA3HN	UA3HNB	4"	48"	1	1
	UA3FP	UA3FPB	5"	36"	1	1
	UA3HP	–	5"	48"	1	–
	–	UA3UPB	5"	240"	–	1
	UA3FR	UA3FRB	6"	36"	1	1
	UA3HR	–	6"	48"	1	–
	UA3FT	–	8"	36"	1	–

Note: Elbows 72" and larger may be shipped in segments. Consult factory for specifics.

Rigid Nonmetallic Conduit – Elbows



ETL Listed to UL 651 in compliance to the NEC



LISTED E35297

Schedule 80 Elbows

Standard Radius

For use with nonmetallic solvent weld fittings.

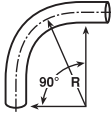
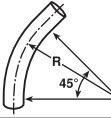
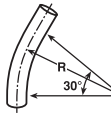
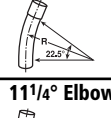
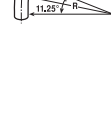
Item	Plain End Part No.	Belled End Part No.	Size	Plain End Std. Ctn. Qty.	Belled End Std. Ctn. Qty.
90° Elbow 	UB9AJ	–	2"	20	–
	UB9AK	–	2½"	10	–
	UB9AL	–	3"	5	–
	UB9AN	–	4"	1	–
	UB9AP	UB9APB	5"	1	1
	UB9AR	–	6"	1	–
45° Elbow 	UB7AJ-UPC	–	2"	20	–
	UB7AK	–	2½"	20	–
	UB7AL	–	3"	1	–
	UB7AN	–	4"	1	–
	UB7AP	UB7APB	5"	1	1
	UB7AR	–	6"	1	–
30° Elbow 	UB6AJ	–	2"	20	–
	UB6AK	–	2½"	1	–
	UB6AL	–	3"	1	–
	UB6AN	–	4"	1	–
	UB6AP	–	5"	1	–
	UB6AR	–	6"	1	–
22½° Elbow 	UB5AL	–	3"	5	–
	UB5AN	–	4"	1	–
	UB5AP	UB5APB	5"	1	1
11¼° Elbow 	UB3AL	–	3"	1	–
	UB3AR	–	6"	1	–

Special Radius

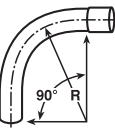
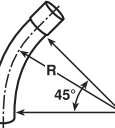
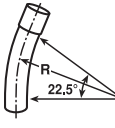
Segment	Plain End Part No.	Belled End Part No.	Nom. Diam.	Radius (in.)	Plain End Std. Ctn. Qty.	Belled End Std. Ctn. Qty.
90° Elbow 	UB9CJ	–	2"	18"	1	–
	UB9DJ-UPC	UB9DJB	2"	24"	1	1
	UB9FJ	UB9FJB	2"	36"	1	1
	UB9HJ	–	2"	48"	1	–
	UB9CK	–	2½"	18"	1	–
	UB9DK-UPC	UB9DKB	2½"	24"	1	1
	UB9FK	UB9FKB	2½"	36"	1	1
	UB9HK	–	2½"	48"	1	–
	UB9CL	–	3"	18"	1	–
	UB9DL	UB9DLB	3"	24"	1	1
	UB9FL	UB9FLB	3"	36"	1	1
	UB9HL	–	3"	48"	1	–
	UB9DN	UB9DNB	4"	24"	1	1
	UB9FN	UB9FNB	4"	36"	1	1
	UB9HN	UB9HNB	4"	48"	1	1
	UB9NN	–	4"	120"	1	–
	UB9FP	–	5"	36"	1	–
	UB9HP	–	5"	48"	1	–
	UB9IP	–	5"	60"	1	–
	UB9FR	–	6"	36"	1	–
UB9HR	–	6"	48"	1	–	
UB9IR	–	6"	60"	1	–	
45° Elbow 	UB7CJ	–	2"	18"	1	–
	UB7DJ	UB7DJB	2"	24"	1	1
	UB7FJ	UB7FJB	2"	36"	1	1
	UB7HJ	–	2"	48"	1	–
	UB7DK	UB7DKB	2½"	24"	1	1
	UB7FK	–	2½"	36"	1	–
	UB7HK	–	2½"	48"	1	–
	UB7CL	–	3"	18"	1	–
	UB7DL	UB7DLB	3"	24"	1	1
	UB7FL	UB7FLB	3"	36"	1	1
	UB7HL	–	3"	48"	1	–
	UB7DN	UB7DNB	4"	24"	1	1
	UB7FN	UB7FNB	4"	36"	1	1
	UB7HN	–	4"	48"	1	–
	UB7FP	–	5"	36"	1	–
	UB7HP	–	5"	48"	1	–
	UB7FR	–	6"	36"	1	–
UB7HR	–	6"	48"	1	–	
UB7IR	–	6"	60"	1	–	
30° Elbow	UB6FN	–	4"	36"	1	–
	UB6FR	–	6"	36"	1	–
22½° Elbow 	–	UB5DJB	2"	24"	–	20
	–	UB5FJB	2"	36"	–	25
	–	UB5DKB	2½"	24"	–	15
	UB5DL	UB5DLB	3"	24"	1	10
	–	UB5FLB	3"	36"	–	1
	UB5DN	UB5DNB	4"	24"	1	5
	–	UB5FNB	4"	36"	–	1
UB5FP	–	5"	36"	1	–	
11¼° Elbow	UB3FP	–	5"	36"	1	–

Note: Elbows 72" and larger may be shipped in segments. Consult factory for specifics.



Schedule 40 Elbows Standard Radius

Available in plain and integral belled end for use with nonmetallic solvent weld fittings.

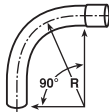
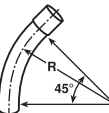
Item	Belled End Part No.	Size	Belled End Std. Ctn. Qty.
90° Elbow 	UA9AJCB-UPC	2"	20
	UA9AKCB-CTN	2 1/2"	10
	UA9ALCB-UPC	3"	25
	UA9AMCB	3 1/2"	1
	UA9ANCB	4"	1
	UA9APCB	5"	1
	UA9ARCB	6"	1
45° Elbow 	UA7AJCB	2"	20
	UA7AKCB	2 1/2"	1
	UA7ALCB	3"	5
	UA7AMCB	3 1/2"	1
	UA7ANCB	4"	1
	UA7APCB	5"	1
	UA7ARCB	6"	1

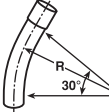
Item	Belled End Part No.	Size	Belled End Std. Ctn. Qty.
30° Elbow 	UA6AJCB	2"	20
	UA6ANCB	4"	1
	UA6ARCB	6"	1

Integral Belled End Dimensions

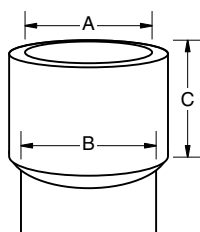

Trade Size	A		B		C	
	At Entrance Max.	Min.	At Bottom Max.	Min.	Socket Depth Max.	Min.
2"	2.405	2.381	2.381	2.357	2.000	1.125
2 1/2"	2.905	2.875	2.883	2.853	3.000	1.469
3"	3.530	3.500	3.507	3.477	3.125	1.594
3 1/2"	4.065	3.965	4.007	3.977	3.250	1.687
4"	4.565	4.465	4.506	4.476	3.375	1.750
5"	5.643	5.543	5.583	5.523	3.625	1.937
6"	6.708	6.608	6.644	6.584	3.750	2.125

Standard Radius Elbow Dimensions

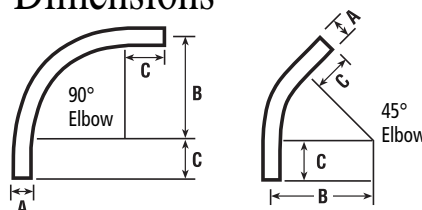

Size	A	B Min. (Radius)	C Min.
2"	2.375	9 1/2"	2"
2 1/2"	2.875	10 1/2"	3"
3"	3.500	13"	3 1/8"
3 1/2"	4.000	15"	3 1/4"
4"	4.500	16"	3 3/8"
5"	5.563	24"	3 5/8"
6"	6.625	30"	3 3/4"

Rigid Nonmetallic Conduit

Typical Properties of Conduit Raw Material Compound

Thermal

	ASTM Test	Typical Values
Co-efficient of Thermal Expansion-inch/inch/°F (properties @ 73.4°F)	D696	3.38 x 10 ⁻⁵
Heat Distortion °F at 264 psi	D648	160°F
Thermal Conductivity BTU (hr.) (ft.) (°F/in.)	N/A	1.3

Mechanical

	ASTM Test	Typical Values
Specific Gravity	D792	1.43 - 1.6
Tensile Strength (psi) @ 73.4°F	D638	5,000-6,500
Izod Impact ft lbs./in. of notch	D256	0.65 - 1.5
Flexural Strength (psi)	D790	12,500
Compressive Strength (psi)	D695	9,000
Hardness (Durometer D)	D2240	85

Electrical

	ASTM Test	Typical Values
Dielectrical Strength volts/mil	D149	1100
Dielectric Constant 60 CPS @ 30°C	D150	4.00
Power Factor 60 CPS @ 30°C	D150	1.93

Impedance (Volts lost per ampere per 100 feet)

	90% P.F.	80% P.F.	90% P.F.	80% P.F.
Steel Conduit	.0118	.0123	.0136	.0142
Schedule 40®	.0105	.0106	.0121	.0122

Using 250 KCmil Cu. conductor. comparable values for other conductor sizes.

Wire Fill

Maximum number of conductors in Schedule 40 PVC conduit

(Based on Table 1, Chapter 9 of the NEC)

Type Letters	Conductor Size AWG, MCM	Trade Size															
		1/2	3/4	1	1 1/4	1 1/2	2	2 1/2	3	3 1/2	4	4 1/4	5	6	8		
THWN	14	13	24	39	69	94	154										
	12	10	18	29	51	79	114	164									
	10	6	11	18	32	44	73	194	160								
	8	3	5	9	19	22	36	51	71	106	136						
THHN	6	1	4	6	11	15	26	37	57	76	98	125	154				
	4	1	2	4	7	9	16	22	35	47	60	75	94	137	236		
FEP (14 thru 2)	3	1	1	3	6	8	13	19	29	39	51	64	90	116	201		
	2	1	1	3	5	7	11	16	25	33	43	54	67	97	169		
FEPB (14 thru 8)	1	1	1	3	5	9	12	18	25	32	49	59	72	125			
	1/0	1	1	3	4	7	10	15	21	27	33	42	61	105			
PFA (14 thru 4/0)	2/0	1	1	2	3	6	8	13	17	22	28	35	51	88			
	3/0	1	1	1	3	5	7	11	14	18	23	29	42	73			
	4/0	1	1	1	2	4	6	9	12	15	19	24	35	61			
PFAH (14 thru 4/0)	250			1	1	1	3	4	7	10	12	16	20	28	49		
	300			1	1	1	3	4	6	8	11	13	17	24	42		
	350			1	1	1	2	3	5	7	9	12	15	21	37		
Z (14 thru 4/0)	400			1	1	1	3	5	6	8	10	13	19	33			
	500				1	1	1	2	4	5	7	9	11	16	27		
	600				1	1	1	1	3	4	5	7	9	13	22		
XHHW (4 thru 500MCM)	700				1	1	1	3	4	5	6	8	11	19			
	750				1	1	1	2	3	4	6	7	11	19			
	6	1	3	5	9	13	21	30	47	63	81	102	128	185	320		
	600				1	1	1	1	3	4	5	7	9	13	22		
XHHW	700				1	1	1	3	4	5	6	7	11	19			
	750				1	1	1	2	3	4	6	7	10	18			

Maximum number of conductors in Schedule 80 PVC conduit

(Based on Table 1, Chapter 9 of the NEC)

Conductor Size AWG, MCM		Trade Size														
		1/2	3/4	1	1 1/4	1 1/2	2	2 1/2	3	4	5					
# 14	THW	4	8	13	24	34	57	82	128							
	THHN	10	19	33	58	81	135	194	0							
12	THW	3	6	11	20	28	47	67	105	183						
	THHN	8	14	24	43	60	100	144	0							
10	THW	3	5	9	16	22	37	54	85	148						
	THHN	5	9	15	27	38	64	92	143							
8	THW	1	2	4	8	11	19	28	44	77	121					
	THHN	1	4	7	13	18	31	45	70	123	195					
6	THW	1	1	3	6	8	14	20	32	56	88					
	THHN	1	3	5	9	13	22	32	50	88	140					
4	THW	0	1	2	4	6	10	15	24	42	66					
	THHN	1	1	3	6	8	13	20	31	54	86					
3	THW	0	1	1	4	5	9	13	20	36	57					
	THHN	1	1	2	5	7	11	17	26	46	73					
2	THW	0	1	1	3	4	8	11	17	31	49					
	THHN	1	1	1	4	5	9	14	22	38	61					
1	THW	0	1	1	1	3	5	8	13	22	35					
	THHN	0	1	1	3	4	7	10	16	28	45					
0	THW	0	0	1	1	2	4	7	11	19	30					
	THHN	0	1	1	2	3	6	8	13	24	38					
00	THW	0	0	1	1	1	4	6	9	16	26					
	THHN	0	1	1	1	3	5	7	11	20	32					
000	THW	0	0	1	1	1	3	5	8	14	22					
	THHN	0	0	1	1	2	4	6	9	16	26					
0000	THW	0	0	1	1	1	3	4	6	11	18					
	THHN	0	0	1	1	1	3	5	8	14	22					
250	THW	0	0	0	1	1	1	3	5	9	14					
	THHN	0	0	0	1	1	1	2	4	6	11	18				
300	THW	0	0	0	1	1	1	3	4	8	13					
	THHN	0	0	0	1	1	1	3	5	9	15					
350	THW	0	0	0	1	1	1	2	4	7	11					
	THHN	0	0	0	1	1	1	3	4	8	13					
400	THW	0	0	0	0	1	1	1	3	6	10					
	THHN	0	0	0	1	1	1	2	4	7	12					
500	THW	0	0	0	0	1	1	1	3	5	8					
	THHN	0	0	0	0	1	1	1	3	6	10					
600	THW	0	0	0	0	0	1	1	1	4	7					
	THHN	0	0	0	0	1	1	1	3	5	8					
700	THW	0	0	0	0	0	1	1	1	3	6					
	THW	0	0	0	0	0	1	1	1	3	6					

Weight Comparison

Prime Conduit Schedule 40® rigid nonmetallic conduit compared to other rigid conduit in pounds per 100 feet (approx.)

Nom. Size	Prime Conduit Schedule 40® Rigid Nonmetallic Conduit	Prime Conduit Schedule 80® Rigid Nonmetallic Conduit	Aluminum	Electrical Metallic Tubing (EMT)	Inter-mediate Metal Conduit (IMC)	Rigid Metal Conduit (RMC)
1/2	18	22	27	30	57	79
3/4	23	29	36	46	78	105
1	35	43	53	66	112	153
1 1/4	48	60	70	96	114	201
1 1/2	57	72	86	112	176	246
2	76	100	116	142	230	334
2 1/2	125	153	183	230	393	527
3	164	212	239	270	483	690
3 1/2	198		288	350	561	831
4	234	310	340	400	625	982
5	317	431	465	Not Made	Not Made	1344
6	412	592	612	Not Made	Not Made	1770

Expansion and Contraction

Temperature Considerations for Rigid Nonmetallic Conduit Compensation for Linear Expansion

Like all construction materials, PVC will expand or contract with variations in temperatures. The coefficient of linear expansion in PVC conduit is 3.38×10^{-5} in./in./°F as compared to 1.2×10^{-5} for aluminum and 0.6×10^{-5} for steel. An expansion fitting is needed whenever the change in length due to temperature variation will be 1/4 in or greater per 352.44 of the NEC.

Add 30°F to the estimated temperature range when conduit is installed in direct sunlight to allow for radiant heating.

An expansion fitting consists of two sections, one telescoping inside another. When installing expansion fittings, alignment of piston and barrel is important. Be sure to mount expansion fitting level for best performance.

For a vertical run, the expansion fitting must be installed close to the top of the run with the barrel jointing down, in order that rain water does not run into the opening. The lower end of the conduit run must be secured at the bottom so that any length change due to temperature variation will result in an upward movement.

Expansion Characteristics of PVC Rigid Nonmetallic Conduit Coefficient of Thermal Expansion = 3.38×10^{-5} in./in./°F

Temperature Change in Degrees F	Length Change in inches per 100 Ft. of PVC Conduit	Temperature Change in Degrees F	Length Change in inches per 100 Ft. of PVC Conduit	Temperature Change in Degrees F	Length Change in inches per 100 Ft. of PVC Conduit	Temperature Change in Degrees F	Length Change in inches per 100 Ft. of PVC Conduit
5	0.2	55	2.2	105	4.2	155	6.3
10	0.4	60	2.4	110	4.5	160	6.5
15	0.6	65	2.6	115	4.7	165	6.7
20	0.8	70	2.8	120	4.9	170	6.9
25	1.0	75	3.0	125	5.1	175	7.1
30	1.2	80	3.2	130	5.3	180	7.3
35	1.4	85	3.4	135	5.5	185	7.5
40	1.6	90	3.6	140	5.7	190	7.7
45	1.8	95	3.8	145	5.9	195	7.9
50	2.0	100	4.1	150	6.1	200	8.1

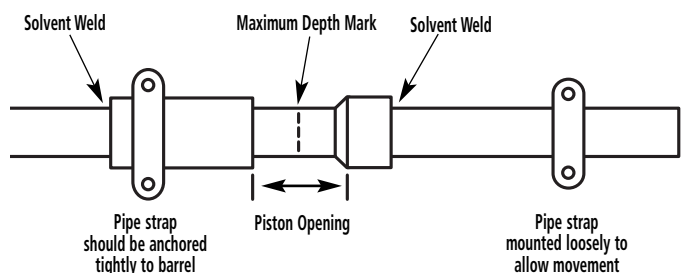

Determine the Piston Opening

The expansion joint must be installed to allow both expansion and contraction of the conduit run. The correct piston opening for any installation condition should use the following formula:

$$O = \left[\frac{T_{\max} - T_{\text{installed}}}{\Delta T} \right] E$$

Where:

- O = Piston opening (in.)
- T max = Maximum anticipated temperature of conduit (°F)
- T inst. = Temperature of conduit at time of installation (°F)
- Δ T = Total change in temperature of conduit (°F)
- E = Expansion allowance built into each expansion fitting (in.)

Example

380 ft. of conduit is to be installed on the outside of a building exposed to the sun in a single straight run. It is expected that the conduit will vary in temperature from 0°F in the winter to 140°F in the summer (this includes the 30°F for radiant heating from the sun.) The installation is to be made at a conduit temperature of 90°F. From the table, a 140°F temperature change will cause a 5.7 in. length change in 100 ft. of conduit. The total change for this example is $5.7 \times 3.8 = 21.67$ " which should be rounded to 22". The number of expansion fittings will be 22" x fitting range (4" for Prime Conduit trade sizes 1/2" through 1-1/2", and 8" for sizes 2" through 6".) The fitting should be placed at 62 ft. intervals (380 x 6). the proper piston setting at the time of installation is calculated as explained above.

$$O = \left[\frac{140 - 90}{140} \right] 4.0 = 1.4 \text{ in.}$$

Insert the piston into the barrel to the maximum depth. Place a mark on the piston at the end of the barrel. To properly set the piston, pull the piston out of the barrel to correspond to the 2.1 in. calculated above. See drawing at lower left.

Summary

1. Anticipate expansion and contraction of PVC conduit in above-ground, exposed installation.
2. Use an expansion fitting when length change due to temperature variation will be 1/4" or greater per 352.44 of the NEC.
3. PVC conduit expands 4.1" for each 100 feet of run and a 100°F temperature change.
4. Align expansion fitting with the conduit run to prevent binding.
5. Follow the instructions to set the piston opening.
6. Rigidly fix the outer barrel of the expansion fitting so it cannot move. Mount the conduit connected to the piston loosely enough to allow the conduit to move as the temperature changes.

Corrosion Resistance of Prime Conduit Schedule 40 and Schedule 80 PVC Conduit

Prime Conduit Schedule 40 and Schedule 80 are generally acceptable for use in environments containing the chemicals below. These environmental resistance ratings are based upon tests where the specimens were placed in complete submergence in the reagent listed. Schedule 40 and Schedule 80 can be used in many process areas where

chemicals not on this list are manufactured or used because worker safety requirements dictate that any air presence or splashing be at a very low level.

If there are any questions for specific suitability in a given environment, prototype samples should be tested under actual conditions.

Acetic Acid 0-20%	Butyl Alcohol	Fluorine Gas – Wet	Mercurous Nitrate	Sodium Arsenite
Acetic Acid 20-30%	Butyl Phenol	Fluorine Gas – Dry	Mercury	Sodium Benzoate
Acetic Acid 30-60%	Butylene	Fluoroboric Acid	Methyl Sulfate	Sodium Bicarbonate
Acetic Acid 80%	Butyric Acid	Fluorosilicic Acid	Methylene Chloride	Sodium Bisulfate
Acetic Acid – Glacial	Calcium Bisulfite	Formaldehyde	Mineral Oils	Sodium Bisulfite
Acetic Acid Vapors	Calcium Carbonate	Formic Acid	Naphthalene	Sodium Bromide
Acetylene	Calcium Chlorate	Fructose	Nickel Chloride	Sodium Chlorate
Adipic Acid	Calcium Chloride	Gallic Acid	Nickel Nitrate	Sodium Chloride
Alum	Calcium Hydroxide	Gas – Coke Oven	Nitric Acid, Anydrous	Sodium Cyanide
Aluminum Chloride	Calcium Hypochlorite	Gas – Natural (Dry)	Nitric Acid 20%	Sodium Dichromate
Aluminum Fluoride	Calcium Nitrate	Gas – Natural (Wet)	Nitric Acid 40%	Sodium Ferricyanide
Aluminum Hydroxide	Calcium Sulfate	Gasoline – Sour	Nitric Acid 60%	Sodium Ferrocyanide
Aluminum Oxychloride	Carbonic Acid	Gasoline – Refined	Nitrobenzene	Sodium Fluoride
Aluminum Nitrate	Carbon Dioxide Gas – Wet	Glucose	Nitrous Oxide	Sodium Hydroxide
Aluminum Sulfate	Carbon Dioxide – Aqueous Solution	Glycerine (Glycerol)	Oils and Fats	Sodium Hypochlorite
Ammonia-Dry Gas	Carbon Monoxide	Glycol	Oils – Petroleum – (See Type)	Sodium Nitrate
Ammonium Bifluoride	Caustic Potash	Glycolic Acid	Oleic Acid	Sodium Nitrite
Ammonium Carbonate	Caustic Soda	Green Liquor (Paper Industry)	Oxalic Acid	Sodium Sulfate
Ammonium Chloride	Chloracetic Acid	Heptane	Palmitic Acid 10%	Sodium Sulfide
Ammonium Hydroxide 28%	Chloral Hydrate	Hexanol, Tertiary	Perchloric Acid 10%	Sodium Sulfite
Ammonium Metaphosphate	Chlorine Gas (Dry)	Hydrobromic Acid 20%	Phenylhydrazine Hydrochloride	Sodium Thiosulfate (Hypo)
Ammonium Nitrate	Chlorine Gas (Moist)	Hydrochloric Acid 0% - 25%	Phosgene, Gas	Stannic Chloride
Ammonium Persulfate	Chlorine Water	Hydrochloric Acid 25% - 40%	Phosphoric Acid – 0-25%	Stannous Chloride
Ammonium Phosphate – Neutral	Chlorosulfonic Acid	Hydrocyanic Acid or Hydrogen Cyanide	Phosphoric Acid – 25-50%	Stearic Acid
Ammonium Sulfate	Chrome Alum	Hydrofluoric Acid 10%	Phosphoric Acid – 50-85%	Sulfur
Ammonium Sulfide	Chromic Acid 10%	Hydrofluorosilicic Acid	Photographic Chemicals	Sulfur Dioxide – Gas Dry
Ammonium Thiocyanate	Chromic Acid 30%	Hydrogen Phosphide	Plating Solutions	Sulfur Trioxide
Amyl Alcohol	Chromic Acid 40%	Hydrogen Sulfide – Dry	Potassium Bicarbonate	Sulfuric Acid – 0-10%
Antraquinone	Chromic Acid 50%	Hydrogen Sulfide – Aqueous Solution	Potassium Bichromate	Sulfuric Acid – 10-75%
Antraquinonesulfonic Acid	Citric Acid	Hydroquinone	Potassium Borate	Sulfuric Acid – 75-90%
Antimony Trichloride	Copper Chloride	Hydroxylamine Sulfate	Potassium Bromide	Sulfurous Acid
Aqua Regia	Copper Cyanide	Iodine	Potassium Carbonate	Tannic Acid
Arsenic Acid 80%	Copper Fluoride	Kerosene	Potassium Chloride	Tanning Liquors
Arylsulfonic Acid	Copper Nitrate	Lactic Acid 28%	Potassium Chromate	Tartaric Acid
Barium Carbonate	Copper Sulfate	Lauric Acid	Potassium Cyanide	Titanium Tetrachloride
Barium Chloride	Cottonseed Oil	Lauryl Chloride	Potassium Dichromate	Triethanolamine
Barium Hydroxide	Cresylic Acid 50%	Lauryl Sulfate	Potassium Ferricyanide	Trimethyl Propane
Barium Sulfate	Crude Oil – Sour	Lead Acetate	Potassium Ferrocyanide	Trisodium Phosphate
Barium Sulfide	Crude Oil – Sweet	Lime Sulfur	Potassium Fluoride	Turpentine
Beet – Sugar Liquor	Deminerlized Water	Linoleic Acid	Potassium Hydroxide	Urea
Benzene Sulfonic Acid 10%	Dextrin	Linseed Oil	Potassium Nitrate	Vinegar
Benzoic Acid	Dextrose	Lubricating Oils	Potassium Perborate	Whiskey
Bismuth Carbonate	Diglycolic Acid	Magnesium Carbonate	Potassium Perchlorate	White Liquor (Paper Industry)
Black Liquor (Paper Industry)	Disodium Phosphate	Magnesium Chloride	Potassium Permanganate 10%	Wines
Bleach – 12.5% Active Cl ₂	Ethyl Alcohol	Magnesium Hydroxide	Potassium Persulfate	Zinc Chloride
Borax	Ethylene Glycol	Magnesium Nitrate	Potassium Sulfate	Zinc Chromate
Boric Acid	Fatty Acids	Magnesium Sulfate	Propane	Zinc Cyanide
Brine	Ferric Chloride	Maleic Acid	Propyl Alcohol	Zinc Nitrate
Breeder Pellets – Dane. Fish	Ferric Nitrate	Malic Acid	Silicic Acid	Zinc Sulfate
Bromic Acid	Ferric Sulfate	Mercuric Chloride	Silver Cyanide	
Bromine – Water	Ferrous Chloride	Mercuric Nitrate	Silver Nitrate	
Butane	Ferrous Sulfate	Mercurous Nitrate	Silver Plating Solutions	
Butadiene		Mercurous Cyanide	Sodium Acetate	

Suggested Format for Specifying Nonmetallic Conduit, Conduit Fittings and Junction Boxes

- A.** The Prime Conduit rigid nonmetallic conduit system shall be installed as indicated on the drawings and as specified herein.
- B.** All wiring shall be installed in Prime Conduit rigid nonmetallic conduit. All conduit shall be secured by means of proper fittings.
- C.** Outlet boxes, fittings and junction boxes shall be used for all outlets, pull boxes and junction points. (Lighting fixtures shall not be supported or hung from PVC junction boxes but be supported in position by other means.)
- D.** Exposed conduits shall be mounted securely by suitable hangers or straps with the maximum spacing of points of supports not greater than indicated by Section 352.30 of the NEC.
- E.** Except where embedded in concrete or direct buried, Prime Conduit conduit shall be supported to permit adequate lineal movement to allow for expansion and contraction of conduit due to temperature change.
- F.** Expansion fittings shall be installed when the length change due to temperature variation will be 1/4" or greater per 352.44 of the NEC.
- G.** Proper care shall be taken when field bending is employed to maintain the internal diameter and wall thickness of the conduit.

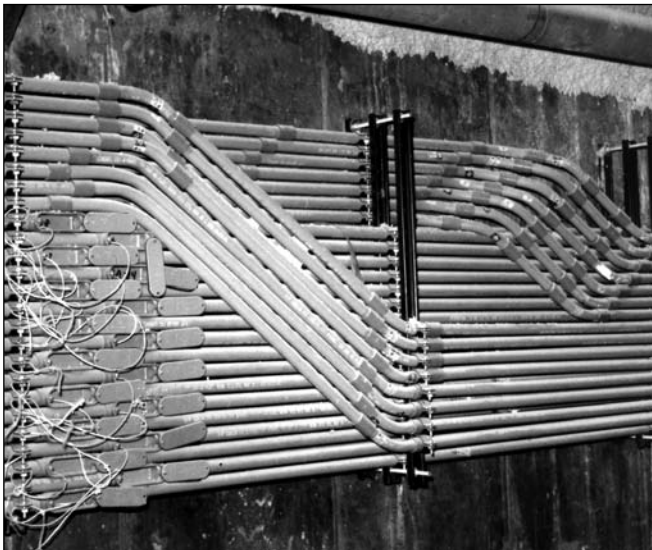
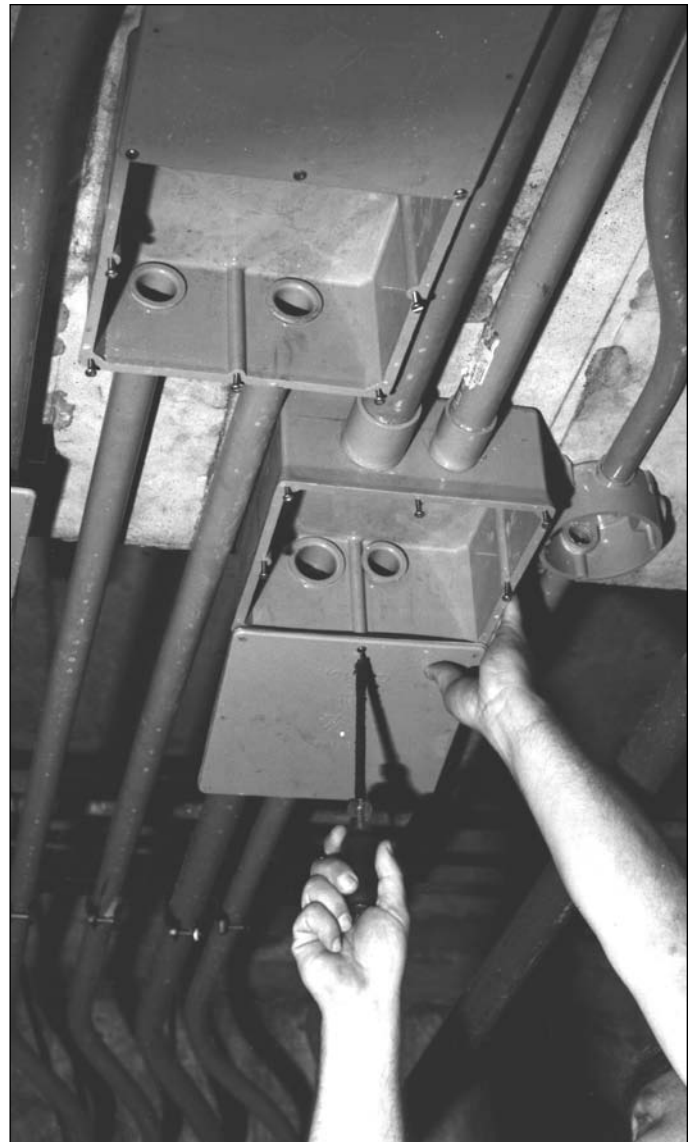

Rigid Nonmetallic Utility Conduit & Elbows

Heavy Wall Rigid Schedule 40 Utility Conduit

Non-UL Listed

- Rated for 90°C conductors or cable
- For direct earth burial and concrete encasement, specifically designed for the power utility specifications.

With Integral Bell*



*Limited geographical area

Part No.		Std. Crate Qty.		Nom. Size	Dimensions		Wall	Wt. Per 100'
20'	10'	20'	10'		O.D.	I.D.		
59610-020	59610-010	4500'	2250'	1 1/2"	1.900	1.610	.145	56
59611-020	59611-010	2800'	1400'	2"	2.375	2.067	.154	75
59612-020	59612-010	1860'	930'	2 1/2"	2.875	2.469	.203	124
59613-020	59613-010	1760'	880'	3"	3.500	3.068	.216	172
59615-020	59615-010	1140'	570'	4"	4.500	4.026	.237	244
59616-020	59616-010	760'	380'	5"	5.563	5.047	.258	331
59617-020	59617-010	520'	260'	6"	6.625	6.065	.280	430
59618-020	59618-010	300'	150'	8"	8.625	7.981	.322	647

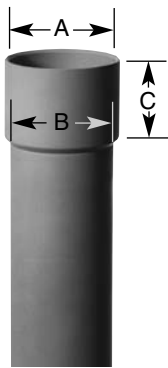

Dimensions in Inches of Utility Conduit Integral Bells

Trade Size	A		B		C
	At Entrance Minimum	Maximum	At Bottom Minimum	Maximum	
1 1/2	1.917	1.927	1.901	1.911	2.750
2	2.405	2.415	2.376	2.386	3.250
2 1/2	2.903	2.913	2.887	2.887	3.250
3	3.543	3.553	3.503	3.513	4.000
4	4.550	4.560	4.504	4.514	4.750
5	5.625	5.635	5.568	5.578	5.750
6	6.693	6.703	6.631	6.641	6.250
8	8.683	8.693	8.631	8.641	6.250

Deep Socket Schedule 40 Utility Elbows with Integral Belled Ends

Segment	Part No.	Nom. Diameter	Radius (in.)	Std. Ctn. Qty.	Std. Ctn. Wt. (lbs.)
90° Elbow	UC9BJB	2"	12"	1	1.44
	UC9DJB	2"	24"	1	2.82
	UC9FJB	2"	36"	1	4.14
	UC9HJB	2"	48"	1	5.15
	UC9DKB	2 1/2"	24"	1	5.00
	UC9FKB	2 1/2"	36"	1	7.15
	UC9DLB	3"	24"	1	6.57
	UC9FLB	3"	36"	1	9.15
	UC9DNB	4"	24"	1	10.59
	UC9FNB	4"	36"	1	13.64
	UC9HNB	4"	48"	1	17.72
	UC9FRB	6"	36"	1	25.80
	UC9HRB	6"	48"	1	32.24
	45° Elbow	UC7FJB	2"	36"	1
UC7CKB		2 1/2"	18"	1	2.27
UC7FKB		2 1/2"	36"	1	4.12
UC7FLB		3"	36"	1	5.00
UC7FNB		4"	36"	1	8.15
UC7HNB		4"	48"	1	9.36
UC7HRB		6"	48"	1	17.19
UC7ITB	8"	60"	1	33.00	

Segment	Part No.	Nom. Diameter	Radius (in.)	Std. Ctn. Qty.	Std. Ctn. Wt. (lbs.)
22 1/2° Elbow	UC5CKB	2 1/2"	18"	1	1.45
	UC5FKB	2 1/2"	36"	1	2.49
	UC5FNB	4"	36"	1	5.18
	UC5FRB	6"	36"	1	11.82
	UC5HNB	4"	48"	1	5.57

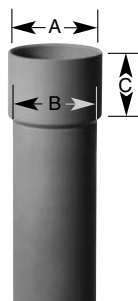

Dimensions in Inches of Utility Elbows Bells

Trade Size	A		B		C	
	At Entrance Min.	Max.	At Bottom Min.	Max.	Nominal Bell Min.	Max.
2	2.395	2.405	2.376	2.386	3.125	3.375
2 1/2	2.901	2.911	2.877	2.887	3.125	3.375
3	3.533	3.543	3.503	3.513	3.875	4.125
4	4.539	4.549	4.504	4.514	4.625	4.875
5	5.609	5.619	5.568	5.578	5.625	5.875
6	6.682	6.692	6.631	6.641	6.125	6.375
8	8.682	8.692	8.631	8.641	6.125	6.375

Rigid Nonmetallic Long Belled Utility Elbows

Non-UL Listed

Specifications

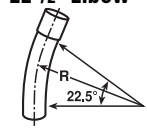
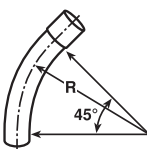
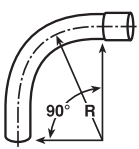
 22¹/₂° Elbow	Part Number	Nom. Diameter	Radius (In.)	Std. Ctn. Qty.	Std. Ctn. Wt. (lbs.)
	UC5FRBLB	6"	36	1	9.6
 45° Elbow	UC7CJBLB	2"	18	1	1.3
	UC7DJBLB	2"	24	1	1.4
	UC7DLBLB	3"	24	1	5.0
	UC7DNBLB	4"	24	1	5.8
	UC7DPBLB	5"	24	1	8.5
	UC7FJBLB	2"	36	1	2.2
	UC7FLBLB	3"	36	1	5.2
	UC7FNBLB	4"	36	1	7.8
	UC7FPBLB	5"	36	1	11.1
	UC7FRBLB	6"	36	1	9.6
	UC7HJBLB	2"	48	1	2.8
	UC7HLBLB	3"	48	1	6.6
	UC7HNBLB	4"	48	1	9.7
	UC7HPBLB	5"	48	1	13.7
	UC7HRBLB	6"	48	1	18.1
 90° Elbow	UC9CJBLB	2"	18	1	1.3
	UC9DJBLB	2"	24	1	1.4
	UC9DLBLB	3"	24	1	5.0
	UC9DNBLB	4"	24	1	5.8
	UC9DPBLB	5"	24	1	8.5
	UC9FJBLB	2"	36	1	2.2
	UC9FLBLB	3"	36	1	5.2
	UC9FNBLB	4"	36	1	7.8
	UC9FPBLB	5"	36	1	11.1
	UC9FRBLB	6"	36	1	9.6
	UC9HJBLB	2"	48	1	2.8
	UC9HLBLB	3"	48	1	12.0
	UC9HNBLB	4"	48	1	9.7
	UC9HPBLB	5"	48	1	13.7
	UC9HRBLB	6"	48	1	18.1